



# INSTALLATION & OPERATING INSTRUCTIONS

## Inbuilt & Insert Wood Fires

### CONTENTS

General Information.....	1
Specifications.....	3
Installation.....	3-7
Inbuilt Zero Clearance Box Installation.....	8-9
Operation.....	10-11
Maintenance.....	12
Replacement Parts.....	13-14
Warranty.....	15

### GENERAL INFORMATION

1. This fire must be installed by a trained wood fire installer, ideally registered with the New Zealand Home Heating Association. Do not allow any makeshift or compromising installation methods as this could result in a house fire. Built in Kent wood fires must be installed according to these instructions.
2. A Building Consent from the Local Authority must be obtained before installing this wood fire, and we suggest that the Insurance Company covering building insurance be advised of the installation.
3. Kent built in wood fires, when installed according to these instructions, comply with the provisions of AS/NZS 2918-2001 "Installation of Domestic Solid Fuel Burning Appliances, including appendix F".
4. The clearances given in these instructions are necessary to prevent overheating of nearby combustibles and drying out of the house structure. They may not be reduced without authorisation.
5. Important: Read all instructions carefully before starting installation. Failure to follow these instructions could result in a fire hazard, and may void warranty.

**RETAIN THESE INSTRUCTIONS FOR FUTURE REFERENCE**

**Important: the installer or seller must leave these instructions with the purchaser**





## SPECIFICATIONS

Model	Model No.	External fire dimensions (mm)			Average emissions	Average efficiency
		Width	Depth	Height		
Rata	KWF295-6938	560	520	554	0.51g/kg	69%
Logfire II	KWF295-6937	560	520	554	0.51g/kg	69%

TABLE 1

## INBUILT & INSERT WOOD FIRE INSTALLATION

To install an above Kent Wood Fire ensure the following required items are available; the correct assembled Wood Fire and Fascia, an adequate floor protector, a zero clearance box if required, the correct flue components and a suitable flashing system for the roof penetration or chimney top to local Council requirements.

### INBUILT FIRE INSTALLATION (TIMBER CONSTRUCTION)

The Kent inbuilt fire requires a zero clearance box when installed into a timber cavity. A floor protector or hearth must be used. The floor protector must extend under the wood fire and not less than 300mm in front of the fuel-loading and ash removal opening. The width of the floor protector should not be less than the width of the wood fire fascia.

Place the wood fire into the desired position and plumb for the ceiling and roof penetrations. Position the wood fire to allow for the Kent triple skin flue systems 250mm outer casing to have a clear path through the roof. Check the proposed route of the flue to ensure it is clear of roof trusses and rafters in the ceiling space or other obstructions. An inbuilt fire must be installed in conjunction with the Kent **KWF298-7374** triple skin flue kit and instructions which are included with the flue kit.

See page 8 for more information on zero clearance box installation.

### INSERT FIRE INSTALLATION (MASONRY CONSTRUCTION)

Prepare the masonry fireplace to accept the selected insert wood fire and flue ensuring installation requirements for width, depth and height measurements are acceptable for the wood fire to fit into the fireplace (Refer to Table 1). Determine whether the flue pipe will fit vertically in the chimney from the heater to the cowl or if an offset is required in the flue. Install the selected Kent wood fire into the prepared fireplace. Once in position and level, fix the fire to the base of the fireplace enclosure with suitable anchors. An insert fire must be installed in conjunction with the Kent **KWF298-6025** standard inset flue kit and instructions which are included with the flue kit.

The wood fire must be restrained against movement in the event of an earthquake. Ensure the Kent wood fire is restrained by fixing the wood fire to the floor protector with two bolts of 6mm minimum diameter through the holes provided in the outer box base. For solid concrete floors, use 8mm DYNABOLTS® or similar, with a minimum depth of engagement into the floor of 50mm.

### INSTALLING THE FASCIA

Unpack the fascia. And remove the top and bottom louvers by lifting the louver up and then rotating it out from the bottom.

Unpack screws and screw locator's from supplied bag. Fit screw locator's to steel fire box clipping them over precut holes in outer box.

Open the door of the fire and manoeuvre the fascia over the open door taking care not to scratch the paint on the door. Align holes in fascia with screw locater holes in outer cabinet.

Close the fire door and secure fascia to fire outer cabinet with screws and washers supplied. Check that door is central in fascia opening and tighten screws once fascia is in the desired position.

Refit louvers by placing in position at a 45° angle into the louver opening. Place the first louver bar at the top behind the front of the fascia. Rotate louver into position and pull down to locate bottom pins in position.

### Insert installation

(Masonry Cavity)

Side Elevation

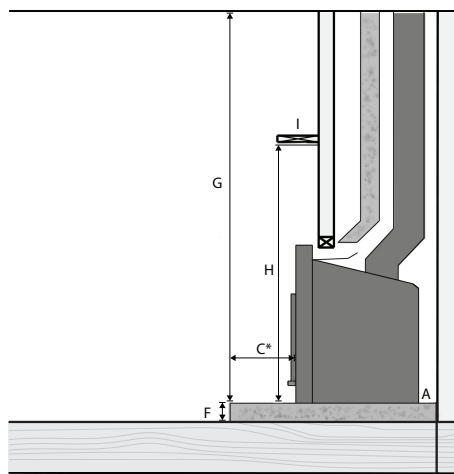

### Inbuilt Installation

(Timber Cavity)

Plan Elevation

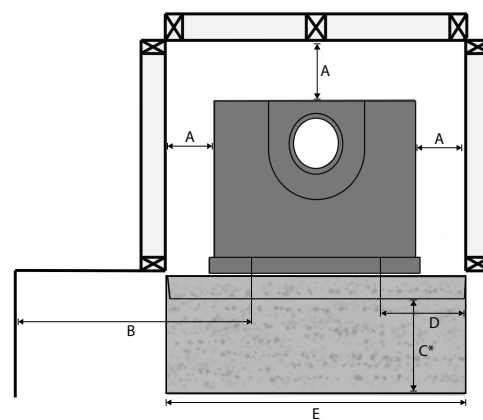

FIG. 1

		Minimum Installation Clearances (mm)								
Model	Model No.	A	B	C*	D	E	F	G	H	I
Rata	KWF295-6938	25	500	300	200	840	59	2000	1200	160
Logfire II	KWF295-6937	25	500	300	200	840	59	2000	1200	160

\* Floor protector from front of fascia.

TABLE 2

## INBUILT FLUE INSTALLATION

Once zero clearance box and 600mm flue transition is in desired place. Plumb up and cut a 260mm square penetration for the passage of the flue pipe and casing through the ceiling. If preferred there can be no ceiling in the framed enclosure. Cut an opening through the roof to position the outer casing through the roof and connect into flue starter transition. Support if necessary with metal bracing angle to suitable anchorage points.

Join the required number of 150mm flue pipes by inserting the swaged ends of the upper piece into the plain end of the lower piece. Drill and fix each length with three stainless rivets or self-tapping screws. It is important that each 150mm flue pipe joint is sealed with commercially available flue sealing compound, including the joint between the fire spigot and the first length of flue pipe.

Assemble as many 200mm inner flue casings together as manageable with swaged ends up, fix lengths together with 3 rivets or self-tapping screws and slide over 150mm flue pipe from the top down to sit in position onto 200mm section of flue transition atop the Zero

clearance box. Add additional 200mm sections of flue as necessary to ensure minimum 1m flue height above roof is achieved (Refer Fig.2 for more detail). Ensure the 150mm flue pipe extends at least 180mm above the 200mm flue casing at the top. Trim flues if required.

Join together as many 250mm outer flue casings as manageable with swaged ends up, fix lengths together with 3 rivets or self-tapping screws and slide over 200mm flue casing pipe from the top down to sit in position onto the 250mm section of flue transition atop the Zero clearance box. Add additional 250mm sections of flue as necessary to finish at the same height as the 200mm flue liner. Trim last section if necessary.

Fit a suitable flashing over the flue and roof penetration hole to flash the outer casing to the roof, seal and fix flashing to roof and outer liner casing with an appropriate waterproof seal.

Place top spreader bracket in place and tighten, slide the cowl transition over the 150mm flue pipe until it rests on the top spreader, fit the Rain-Hat cowl. Note; Rain-Hat must be removable for cleaning. In high wind zones secure in place with a self tapper screw.

Where a flue terminates more than one full flue section above the roof penetration, it must be restrained with guy wires or support bracing bars for stability in high wind conditions.

The flue system should be vertical and without bends. If an offset is required, it should be as close to the wood fire as practicable and should not be offset more than 500mm from the centre line of the flue stub. Clearances from the flue pipe to combustible materials must be maintained. Restrictions or leaks in the flue system may reduce the draught, and, in severe conditions, could cause smoke to enter the room.

NOTE: The flue pipe shall extend not less than 4.6m above the top of the floor protector.

The flue cowl must be at least 0.6m above the highest point of the roof, if within 3 metres of the ridge. The flue cowl must be at least 1m above the roof penetration if more than 3 metres from the ridge (Refer Fig. 2).

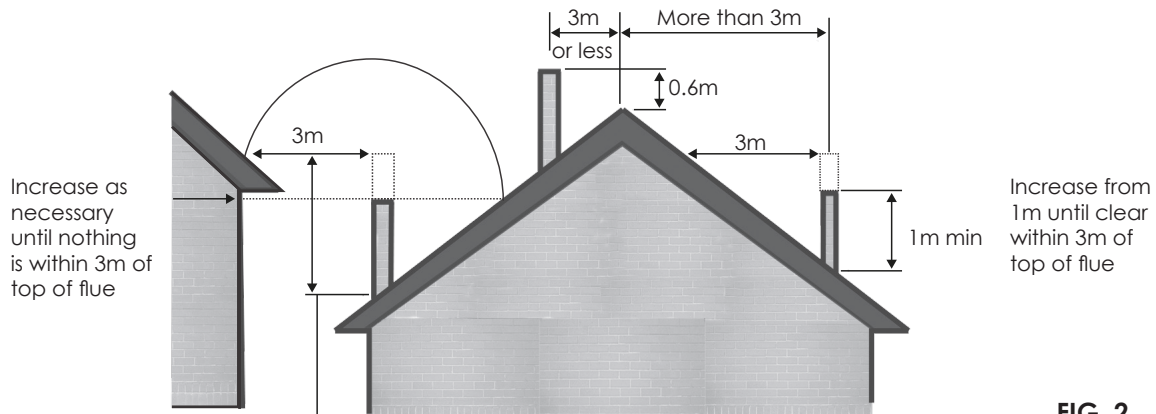

FIG. 2

No part of a building, or any adjacent object, may be above the flue in a circular area of 3 metres from the flue exit.

These heights are given as a minimum, and in actual practice the presence of surrounding structures, trees, fences, etc. may necessitate additional flue height for satisfactory performance.

## INSERT FLUE INSTALLATION

Determine whether the flue pipe will fit vertically in the chimney from the heater to the cowl. An adjustable bend may be required to offset the flue from the heater in order to clear part of the chimney structure. If an offset is required, it should be fitted to the flue outlet on the heater, so that the flue pipe itself is vertical. The flue pipe should not touch the masonry.

Check chimney for accepting flue is in sound condition, and fixing of outer casing or chimney cap flashing to chimney crest is achievable.

Install the selected Kent wood burner into the prepared fireplace. Once in position and level fix the fire to the base of the fireplace enclosure with suitable anchors through the supplied fixing points in the base of the wood burners outer box.

Determine the total length of flue pipe and outer casing required by measurement.

Assemble the flue pipe lengths with the swaged ends of the upper section inside the plain ends of the lower pieces. Drill and fix each length with three stainless rivet's or self-tapping screws. This may be done on the ground and then the whole assembled length lowered down the chimney to sit in the fire spigot. Note: It is important that each flue joint is sealed with commercially available flue sealing compound, including the joint between flue spigot and the first length of flue pipe.

Locate the flue or adjustable bend into the flue outlet of the heater and ensure flue pipe or bend is sealed into fire spigot with flue sealant.

Ensure the top of the chimney terminates at a point complying with the guidelines noted in FIG. 2 and that the flue pipe extends above the 250mm casing flue by 180mm. Trim flues as required. Secure the top spacer bracket to the flue pipe and ensure the slots fit snugly inside the 250mm chimney liner.

Secure outer liner to chimney cap flashing, or cement outer liner in position with mortar or other suitable sealing compound ensuring that there are no gaps and a water tight seal is achieved.

**Note:** some areas require a chimney cap flashing to be used (not supplied).

Slide the cowl transition over the flue pipe until it rests on the top spreader. Fit and secure rain hat or cowl noting it must be readily removable for flue sweeping.

## DOOR HANDLE AND DOOR

The door handle is pre-fitted and should not require any adjustment on assembly of the fire.

To ensure the door is shutting correctly cut a plain piece of paper about 50mm wide and place between the open door and the door frame. Close the door and try to pull the paper out. If the paper can be freely pulled out, the door will need to be adjusted so when the door and handle is in the locked closed position pressure is applied to the paper strip ensuring door seal is seated correctly.

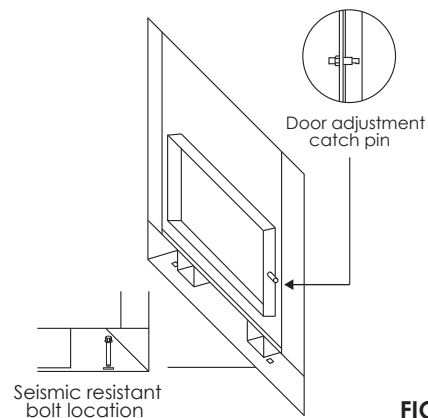

FIG. 3

If the handle has too much sideways movement the back nut on the hinge screw will need to be released. Tighten the hinge screw with an Allen key until the desired movement is achieved (not too tight, not too loose), then re-tighten back nut to hold screw in position.

Any adjustment required to maintain the correct fit of the door is made at the door catch pin on the right side of the door lip. To adjust the fit of the door catch, loosen the lock nut and turn the catch pin to loosen or tighten the fit. Re-tighten the lock nut (Refer Fig 3).

## TOPOGRAPHY OF THE LAND

Given that the Topography of the land and atmospheric conditions vary considerably from house to house, it is possible for a wood fire flue to comply with the minimum requirements set out in FIG 2 but still fail to extend upward far enough to establish ambient updraft. It is not uncommon for fireplaces in houses that are surrounded by hills or trees, or that are located by large bodies of water to need more flue height than the minimum required by code.

## WIND CONDITIONS

Wind causes pressure changes inside as well as outside a house. The design of the house can influence the pressure environment around and in your home, the effect of wind on the home can be complex and unpredictable. Care needs to be taken to ensure the flue termination is in a good clear position. Your installer should be able to give advice on the best flue termination position for your situation. Problems associated with wind noise or draft are almost never caused by the wood fire itself and in general a flue that penetrates the roof near the peak and is more than 600mm above the ridge is unlikely to be affected by wind.

## PRESSURE DIFFERENTIAL, VENTING AND EXTERNAL AIR INTO THE BUILDING

Negative house pressure is a common problem that can cause wood burning appliances to have trouble lighting and performance issues, in some cases causing smoke to be spilled back into the room. Kitchen and bathroom exhaust fans, air-conditioning units, and well-sealed, insulated homes are more likely to have a negative pressure problem. Larger homes with multiple levels are also likely candidates, however any house can have a negative pressure problem. Care needs to be taken at the design or installation stage to ensure the building has adequate ventilation to ensure draft in the flue system is always to the outside.

## TYPICAL FLUE INSTALLATION FOR INBUILT AND INSERT FIRES

### Insert Flue installation

Masonry Cavity

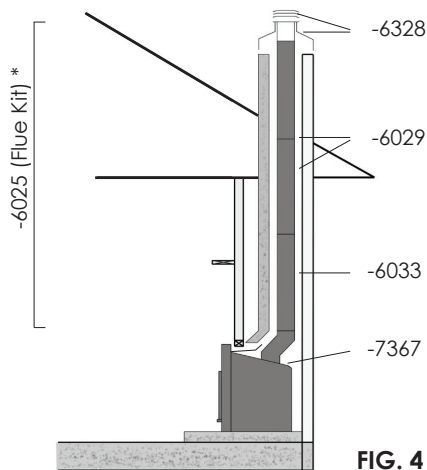

FIG. 4

### Inbuilt Flue Installation

Timber Cavity

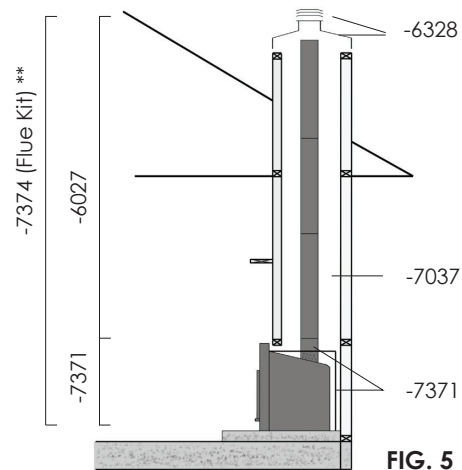

FIG. 5

Model No.	Description
KWF298-6025 *	Kent Insert Flue Kit (3 x 150 Ø x 1200mm stainless steel flue, 1 x 150 Ø x 600mm stainless steel flue, 1 x 250 Ø x 600mm galvanised flue, 1 x cowl hat & spider)
KWF298-7374 **	Kent Rata / Logfire II Zero Clearance Box with Inbuilt Flue Kit (3 x 150/200/250 Ø x 1200mm flue, 1 x 150 Ø x 600mm stainless steel flue, 1 x cowl hat & spider, 1 x zero clearance box)
KWF298-7371	Kent Rata / Logfire II Zero Clearance Box and 600mm Flue Transition
KWF298-6027	Kent Inbuilt Flue Kit (3 x 150/200/250 Ø x 1200mm stainless steel flue, 1 x cowl hat & spider)
KWF298-6033	Kent Single Length Stainless Steel Flue 150 Ø x 1200mm
KWF298-6328	Kent Stainless Steel Hat and Cowl
KWF298-7037	Kent Extension Flue 150/200/250 Ø x 1200mm
KWF298-7367	Kent Fixed Offset 150 Ø x 100mm
KWF298-6029	Kent 150 Ø x 1200mm Stainless Steel Flue twin pack

# INBUILT ZERO CLEARANCE BOX INSTALLATION

## FOR THE INSTALLATION OF THE KENT LOGFIRE II AND RATA WOOD FIRES INTO A WALL CAVITY.

This product has been designed and manufactured to comply with the requirements of AS/NZS2918:2001. For safe installation of a Kent Logfire II and Rata into a wall cavity instead of a masonry fireplace or chimney. It is important that these instructions are followed exactly, and that no substitutions are made for components supplied with the kit, or material listed. It is suitable only for the Kent Logfire II and Rata models manufactured from 2006. It is not suitable for older models of Kent Logfire or other brand fires.

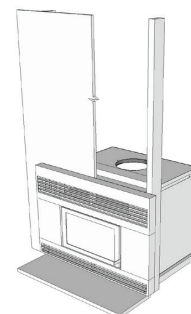

### INSTALLATION:

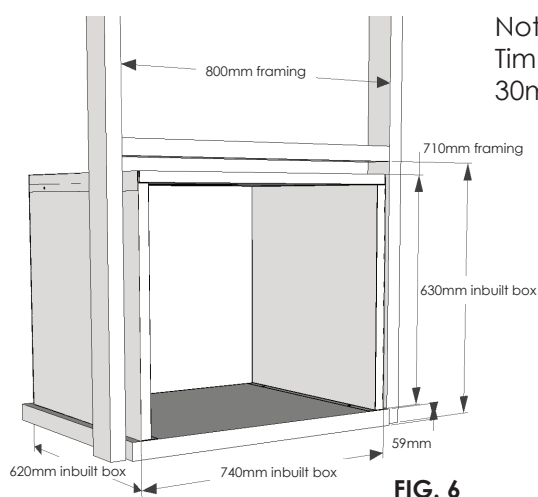

Note:  
Timber framing to have a minimum clearance of 30mm on the sides, rear and top (Fig. 6).

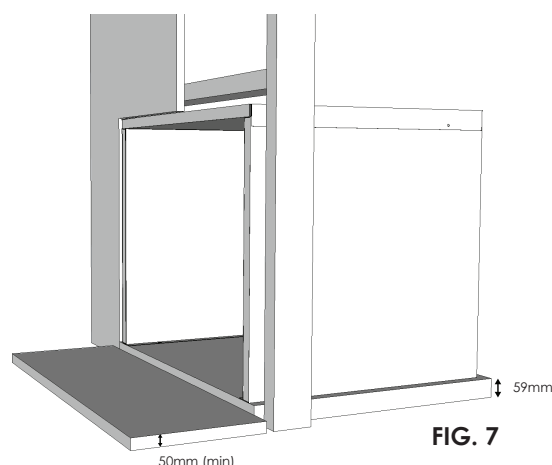

Note:  
9mm non-combustible facing panel to have a minimum clearance of 30mm on the sides and to be set 3mm up from the top of the inbuilt box (Fig. 7).

The Kent Inbuilt zero clearance box must be installed onto a concrete base with a minimum thickness of 59mm, and must be a minimum of 785mm wide and 640mm deep behind the face of the wall, with an additional 360mm forward of the wall face to allow for the front clearance once installed.

Timber framing around the Inbuilt box must have a minimum clearance of 30mm between it and the outer surface of the Inbuilt box.

Frame up an opening in the wall that is 800mm wide and 719mm above the original floor line (660mm above the top surface of the concrete floor protector).

Fix non-combustible board with a minimum overall size of 950mm wide x 1200mm high, to the framing. Please note, it is most often easier to use a full sheet of non-combustible board and go from floor to ceiling. Once framing is in place, align the zero clearance box with the front edge level to the face of the wall.

The non-combustible board opening must be 3mm or more from top and 30mm from each side of the zero clearance box to allow for air flow through the gap, for cavity and flue casing cooling.

Secure in position with screws or DYNABOLTS through the angle brackets attached to the foot on each side on the zero clearance box (see quick assembly guide, step 4, page 9).



## QUICK ASSEMBLY GUIDE:

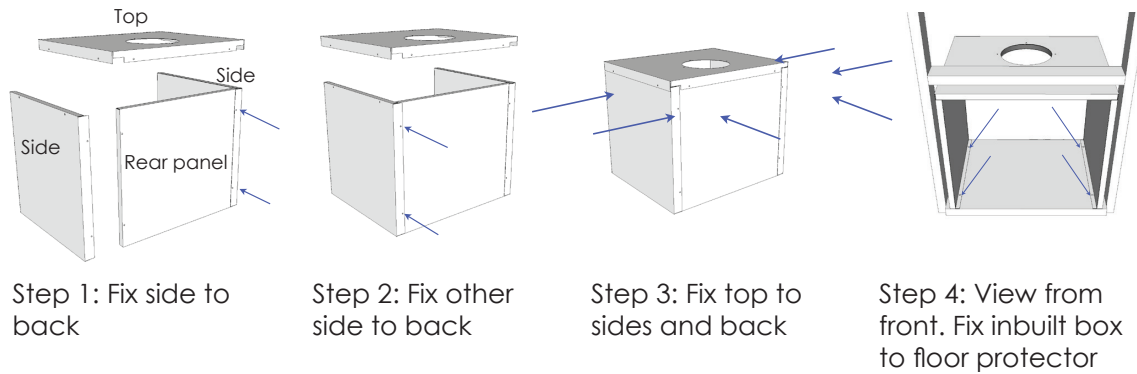

## FLUE STARTER TRANSITION:

The Inbuilt box is supplied with a Flue Transition Kit of 600mm long flue components. These components are specially ventilated and must be used at the bottom of the flue system. The 150mm stainless steel flue fits into the standard flue spigot of the fire. The 200mm casing sits down onto the top of the firebox casing, with the venting holes at the bottom. The 250mm casing fits into the socket of the Inbuilt box with the venting holes at the bottom. No substitutions may be made for these components.

Additional extension kits of 150mm, 200mm, and 250mm flue must be purchased to suit the particular installation. At least three flue extension lengths will be required to meet the minimum height requirements of 4.6m above the floor protector. Refer to the Logfire II or Rata instructions for general flue requirements.

The Flue extensions are installed in the usual way on top of the Flue Transition Kit.

**Before the wood fire is used, ensure that a Compliance Certificate (supplied by a Registered Installer and/or Territorial Authority Inspector) is obtained for the user. We encourage initial demonstrations on how to light and operate the fire to ensure the user can confidently operate the fire for safe and efficient performance.**

## OPERATION

Thank you for purchasing a Kent wood fire. Used and maintained correctly, it will provide you with many years of warmth in your home. Kent wood fires have been the main source of heating for many Kiwi homes, for over 40 years.

**Please ensure your installer completes and signs the warranty registration card in this booklet. We encourage you to read the warranty conditions and draw your attention to improper fuel use.**

### LIGHTING

On initial light up, the presence of smoke may be noticed. This is normal and will dissipate quickly. **DO NOT BURN YOUR WOOD FIRE TOO QUICKLY TO BEGIN WITH.** Allow several small fires to build up a layer of ash in the wood fire, and cure the paint before using maximum power.

1. Pull out the air control knob, until it is fully open.
2. Place several pieces of crumpled newspaper in the base of the firebox, and criss-cross with 8-10 pieces of dry split kindling. Stack several pieces of dry split firewood no greater than 30cm in length on top of the kindling.
3. Ignite the paper and leave the door slightly ajar (resting it on the latch). Let the fire establish itself for 4-5 minutes, then open the door and add some more pieces of wood. Do not leave the fire unattended during this process.
4. Close the door fully, but leave the air control fully open until the wood is well alight and burning brightly.



**Note:** It may be necessary in some cases to leave the door ajar for longer periods and use more small kindling in order to establish enough heat to warm up the flue. Only when the flue is sufficiently warm to create the necessary draft to maintain the fire may the door be fully closed. It may take trial and error to find a lighting procedure that suits your situation.

### NORMAL OPERATION ONCE THE FIRE IS ESTABLISHED

The Kent wood fire requires fresh air for optimal burning, and this must come from outside the house. A normal house will allow enough air in through incidental openings to satisfy this. We recommend that a source of air be located near the wood fire for best performance. This can be simply a window that is left ajar while the wood fire is in use. If this is not possible, and the house is particularly air-tight, a vent may need to be installed next to the wood fire to provide the air required. Lack of air will lead to a wood fire that is hard to light and get going, or in bad cases, to smoke spilling back into the room.

While an air control is fitted, it is recommended that, for the cleanest operation, this is left fully open and the amount of heat generated is adjusted by the amount of fuel that is used. The heater burns cleanest when it is running at a high rate.

Once the fire is well established, the output can be regulated by the amount of wood that is used.

To reload the fire, open the air control fully, and then open the door. Note that the fire burns hottest at the front of the firebox and so there may be unburnt wood at the back when it comes time to reload. This is normal. Rake through the contents to move any unburnt wood forward and then place the desired amount of wood into the firebox. Close the door.

The view of the flame through the glass door will give you the best indication of how your wood fire is performing. In order to accomplish maximum combustion performance, the fire should give a rolling, boiling flame pattern. At reduced setting the flame will be slower.

For all practical purposes, the air control should be fully open when there is unburnt wood in the wood fire. Fire holding periods may be increased by turning down the air control, this is generally at the cost of greater emissions and creosote production. At low settings, creosote may condense on the glass, reducing the visibility of the fire. The best indication that the fire is operating correctly is that the glass remains clean, without build-up of black or brown deposits. Some whitish bloom on the glass is normal and does not generally indicate a fault in operation.

The way you burn your wood fire will also determine what is happening up the flue. Continued burning at high rates with a good clean flame will minimise smoke emission and soot and creosote deposits in the flue.

## **CLEANING OUT THE WOOD FIRE**

Your wood fire should require minimum cleaning. If the wood fire is operated correctly, and according to the instructions most of the ash will be consumed by the fire and a bed of ash will be maintained that does not build up to any great extent.

If you find that you have to clean out ashes every day or so, it indicates that the wood fire is not being operated correctly. Either excessively wet wood, unseasoned wood or foreign materials are being burnt, or the air control is being turned down too much.

Don't clean out the firebox completely during the heating season. Leave about 25mm of ash in the bottom of the firebox after cleaning. These ashes in the bottom of the wood fire assist the burning process, by insulating the firebox and allowing air circulation under the fire bed.

When emptying ashes use a metal container with a tight fitting lid. Do not use this container for any other purpose. The closed container of ashes should immediately be taken outdoors to a location well away from any combustible materials, pending final disposal. If the ashes are to be disposed of by burial in the garden or otherwise locally dispersed, they should be retained in the container until they are completely extinguished and cold. This may take several days.

## **CREOSOTE FORMATION AND NEED FOR REMOVAL**

We recommend the flue of your wood fire is inspected before use at the start of each heating season and also periodically during the season. When you are able to operate the wood fire without creating creosote deposits, the interval between inspections may be increased, but the flue must always be inspected and cleaned at least once a year.

The flue should be swept by a professional chimney sweep to remove any build-up of creosote and soot. A professional sweep should also advise of any problems that may be detected in the inspection of the flue and offer advice on any repair and replacements. Your Kent wood fire requires minimal maintenance, and will keep its good looks for a long time with just a little attention.

**DO NOT BURN TREATED TIMBER OR UNSEASONED WOOD.**



# REPLACEMENT PARTS

Replacement parts must be original Kent parts. Maintenance required should be carried out by a suitably qualified service technician. Please consult your Kent retailer for their details. The wood fire should not be modified in any way except in accordance with instructions supplied by Kent.

## KENT AIR TUBES

Rata & Logfire II



Top front  
KWF299-6905

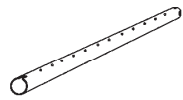

Top rear  
KWF299-6906

All Fires



Air Tube Spacer  
KWF299-6257

All Fires

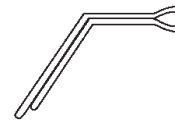

Air Tube Pin  
KWF299-6900

The air tube in your Kent wood fire is an important part of the appliance and helps ensure a clean, efficient and controllable burn. However, air tubes are a consumable item and need to be replaced from time to time as they are likely to degrade with continual exposure to the extreme heat generated in the fire box.

The life of the air tube will depend on what is burnt in the fire, how hot the fire usually burns and also the ash level. If the ash level is allowed to build up. This can push embers up and into the holes stopping the air cooling effect. It also means hot embers are in closer proximity to the tube, increasing the temperature exposure. Ensure ember levels do not build up to high, when reloading the fire with fuel.

### Replacing air tubes:

1. Remove bricks from both sides
2. Remove the pin from the end of the old tube
3. Slide tube to one side, this will release the opposite end
4. Pull released end up and towards the door and remove
5. Reverse process for installation of new tube

## KENT BAFFLES

**Rata & Logfire II**  
(Top rear view)

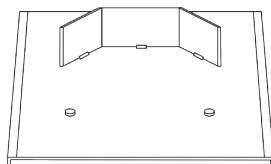

Includes Promat bricks  
Dimensions (mm): 480 x 200

KWF299-7043

The baffle in your Kent wood fire is an important part of the appliance and helps ensure a clean, efficient and controllable burn. However, baffles and Promat bricks are a consumable item and are designed to be replaced as they are likely to degrade with use due to exposure to the extreme heat of the fire.

The life of the baffle will depend on what is burnt in the fire and how hot the fire usually burns.

### Replacing baffle:

1. Remove front air tube by pulling locking pin out of air tube spacer slide ring on the left top side. Slide spacer ring to the right and slide air tube horizontally to the left. Right hand side of the air tube will drop out of the keyed side.
2. Swing air tube out through door.
3. Lift baffle plate up off side support rails and pull forward 40mm. Push one side up as high as you can while letting the other side drop over the side support rail.
4. Keep at a 30° angle and remove it through the door.
5. Reverse process to install new baffle. And air tube.
6. Ensure baffle is sitting firm against back.

## KENT FIRE BRICKS

**Rata & Logfire II**

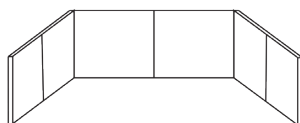

Dimensions (mm):  
2 - 205 x 176 x 25  
4 - 180 x 176 x 25

KWF299-7040

The fire bricks in your Kent wood fire are an important part of the appliance and helps ensure a clean and efficient burn. However, fire bricks are a consumable item and are designed to be replaced as they are likely to degrade with use due to exposure to the extreme heat of the fire.

The life of the fire bricks will depend on what is burnt in the fire and how hot the fire usually burns and also any damage sustained from wood not being positioned correctly.

At the risk of damaging the fire box, fire bricks should be replaced when they are damaged enough that they no longer remain in place and cannot perform their intended function. Fire bricks which are only cracked but still remain in place do not need to be replaced and are safe to use.

**NOTE:** For all other fire parts please contact your Kent dealer.

# WARRANTY

## STANDARD WARRANTY

Your Kent wood fire is warranted for 10 years on the firebox with the exception of the following Kent parts: glass, glass seal, door seal, fire bricks, flue, secondary air system and removable baffle parts which will all have a 12 month warranty (parts only) provided they have been installed by an approved installer. The warranty does not apply to normal wear and tear, misuse or neglect, nor if parts of the wood fire are replaced with non genuine Kent parts. Kent recommends an annual service and flue sweep with replacement of parts if recommended to obtain maximum life out of your wood burner.

## CONDITIONS

Your Kent wood fire must be installed in accordance with the manufacturer's instructions and all applicable standards, regulations and by-laws. Your Kent wood fire must be installed with an approved flue system. Failure to do so may void your warranty in its entirety. The company is not liable for any consequential damage by a failure or defect covered in this warranty. All claims against the warranty must be directed in the first instance to the retail outlet from which you made your purchase. Any repairs undertaken without the express authority of Kent will invalidate this warranty. This warranty does not cover damage caused by wetbacks/water boosters, burning improper fuels (driftwood/treated wood/coal or plastic-based waste), or installation, plumbing and sweeping work done by others (the installer is liable for any incorrect procedures or poor workmanship).

## TRANSFERABILITY

Your Kent wood fire warranty is transferable on the sale of the home where the wood fire is installed. Nothing in this warranty is intended to limit any conditions of the warranty right or remedy pursuant to the Consumer Guarantee Act 1993, except to the extent permitted under the Act. Your Kent wood fire is intended for domestic use only and the warranty is not valid for wood fires to be used for business purposes. Kent reserves the right to alter or amend specifications or designs of its product without prior notice.

### KENT 10 YEAR WARRANTY REGISTRATION

Please keep this copy for your records.

MODEL:.....

SERIAL NUMBER:.....

RETAILER:.....

PURCHASE DATE:.....

INVOICE NUMBER:.....

(Please keep your invoice attached to your warranty record)

INSTALLER NAME:.....

DATE INSTALLED:.....

NZ HOME HEATING  
ASSOCIATION NUMBER:.....

INSTALLER SIGNATURE:.....

Kent products are distributed by:  
Aber Holdings Ltd T/A Aber,  
17 Mainstreet Place, Te Rapa,  
Hamilton 3200  
Free Phone: 0800 161 161  
Free Fax: 0800 163 163  
[www.aber.co.nz](http://www.aber.co.nz)

Product specifications are at date of publication and are  
subject to change without notice.  
KWF299-7119 -01/18



[www.kent.co.nz](http://www.kent.co.nz)